

# Radio Dimmer and LED Eye-Lights



**The Radio Dimmer and LED Eye-Lights** combines a brilliant 25W LED array with a wireless dimmer. The dimmer can be controlled by the **FI + Z Hand Unit, Radio Micro Force**, or **Focus/Iris** wireless units. The high efficiency of the lamps gives them enough punch for exterior or bright interior use. Most importantly, their color temperature remains nearly constant, without flicker, over 5 stops of intensity change. A perfect light for Steadicam® or other mobile applications.

Two versions of LED Lamps are available. The "Daylight" lamp has a color temperature in the range of 5000 ~ 7000°K (nominal 5500°K), and the "Warm White" lamp has a color temperature in the range of 3600 ~ 4500° (nominal 4000°K). Removable filters are provided to adjust the effective color temperatures to 5500°K and 3200°K respectively. Please note that conventional temperature meters do not give accurate color temperature or filtration data for these LED lamps.

A holographic diffusion filter provides a smooth distribution of light without hot spots. The lamp has a standard ¼-24 mounting plate and the Dimmer comes with an adjustable clamp for mounting to matte box rods from 15 – 19mm diameter.

The Radio Dimmer can also be used to control the intensity of **Kino Flo Lamps**. Both the 6" Kamio and Mini Flo models may be used. In both cases, the corresponding Kino Flo ballasts are required. The maximum dimming range is approximately 2 ½ stops.

## LED Lamp Photometric Data:

Maximum Illuminance (3m on axis)                      7fc (690 lux)

The light intensity fall-off with angle:

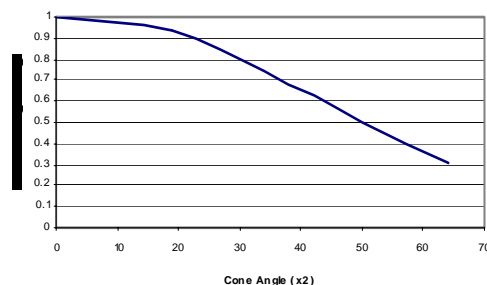

## Mechanical Dimensions

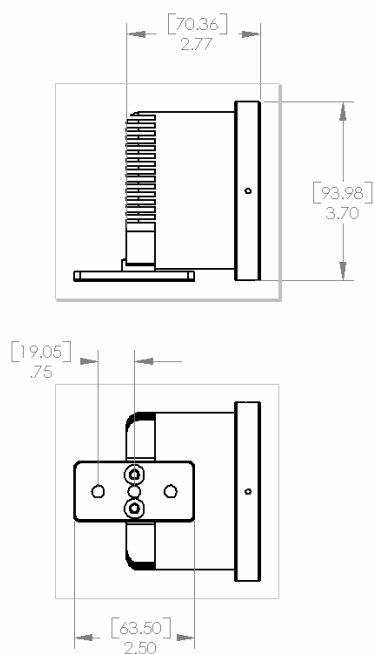

**Weights:**

Dimmer Module	11.1 oz (300g)
Lamp	12.8 oz (350g)

**Power requirements:**

Voltage:	12 -30 VDC
Max Current:	1.2A

<b>Product Number</b>	<b>Description</b>
5010	Radio Dimmer with Clamp Bracket for matte box rods and LED Light (choose 5012 or 5013), cable 5014, and power cable (choose 5020 or 5021)
5011	Radio Dimmer with Clamp Bracket
5012	LED Light (daylight)
5013	LED Light (warm white)
5014	LED Light to Dimmer Cable
5015	Dimmer to Kino Flo Ballast
5020	Power Cable (XLR3 Panavision Polarity)
5021	Power Cable (XLR3 Arri Polarity)